

THIS DRAWING IS UNPUBLISHED. RELEASED FOR PUBLICATION
 © COPYRIGHT BY TYCO ELECTRONICS CORPORATION. ALL RIGHTS RESERVED.

LOC	DIST	REVISIONS			
P	LTR	DESCRIPTION	DATE	DWN	APVD
DW		ECR-08-001294, ADD NEW P/N 2--1	21JAN08	SC	WK

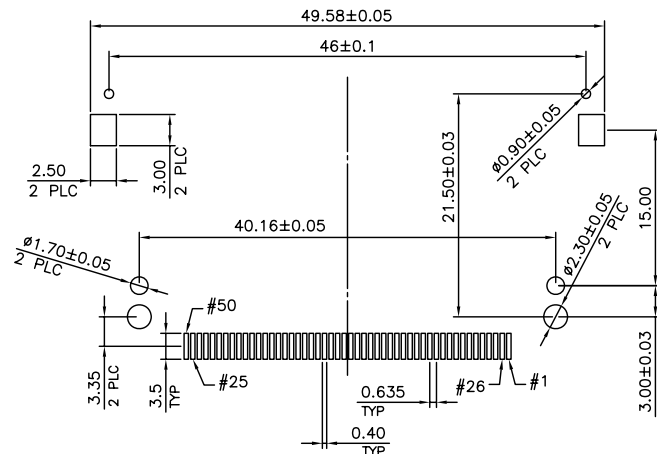
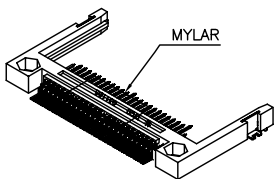
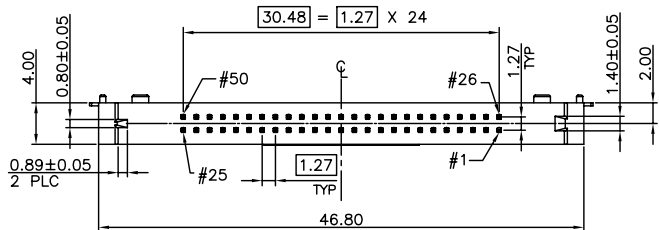

- NOTE:
- MATERIAL:
HOUSING: THERMOPLASTIC., UL 94V-0, COLOR: NATURAL.
CONTACT: BRASS, THICKNESS=0.25mm.
MOUNT EAR: BRASS, THICKNESS=0.30mm.
 - FINISH:
CONTACT: GOLD PLATED (SEE TABLE) IN CONTACT AREA,
100u" MIN. MATTE TIN ON SOLDER TAILS,
50u" MIN. NICKEL UNDERPLATED ALL OVER.
MOUNT EAR: 100u" MIN. TIN PLATED.
 - CONNECTOR REQUIRES USE OF 2 - SIZE M2 SCREWS FOR FASTENING TO PRINTED CIRCUIT BOARD.
 - REFLOW SOLDER CAPABLE TO 260°C PER TE SPEC 109-201, CONDITION B.

REEL	W/	15μ"	2-1734451-1
TRAY	W/	GOLD FLASH	1-1734451-3
		30μ"	1-1734451-2
	W/O	15μ"	1-1734451-1
		30μ"	1734451-2
	15μ"	1734451-1	
PACKAGE	MYLAR	MIN. GOLD THICKNESS	PART NUMBER

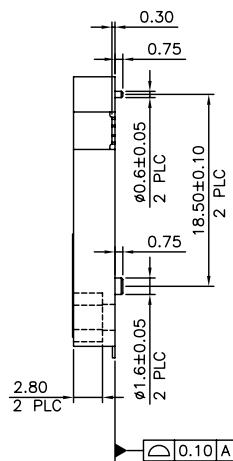
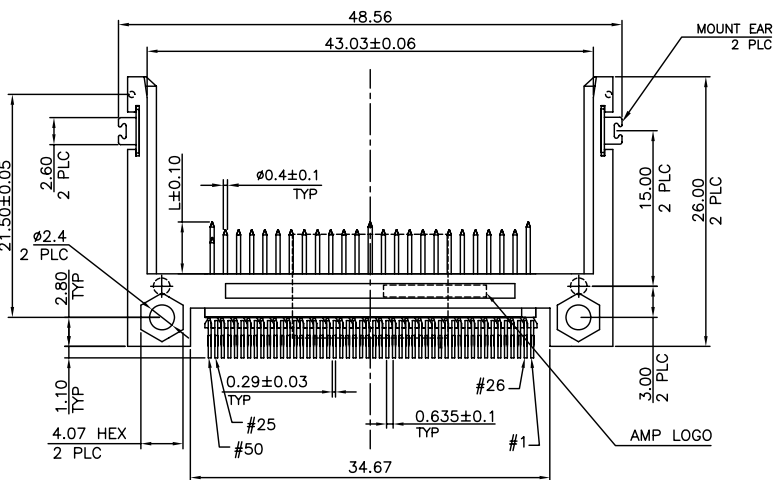

POWER	5.00mm
GENERAL	4.25mm
DETECT	3.50mm
PIN TYPE	INTERFACE DIM. L

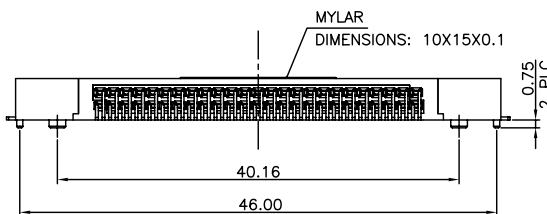

THIS DRAWING IS A CONTROLLED DOCUMENT.		DWN S. CHIEN 21JAN2008	Tyco Electronics Tyco Electronics Corporation Taipei, Taiwan													
DIMENSIONS: MM		CHK S. HOU 21JAN2008	NAME													
TOLERANCES UNLESS OTHERWISE SPECIFIED:		APVD W. KODAMA 21JAN2008	PIN HEADER SLIM TYPE, 50 POS, TOP BOARD, COMPACT FLASH CARD													
<table border="1"> <tr><td>0 PLC</td><td>± -</td></tr> <tr><td>1 PLC</td><td>± 0.30</td></tr> <tr><td>2 PLC</td><td>± 0.20</td></tr> <tr><td>3 PLC</td><td>± -</td></tr> <tr><td>4 PLC</td><td>± -</td></tr> <tr><td>ANGLES</td><td>± 2'</td></tr> </table>		0 PLC	± -	1 PLC	± 0.30	2 PLC	± 0.20	3 PLC	± -	4 PLC	± -	ANGLES	± 2'	PRODUCT SPEC 108-57134	QUALIFICATION TEST REPORT	
0 PLC	± -															
1 PLC	± 0.30															
2 PLC	± 0.20															
3 PLC	± -															
4 PLC	± -															
ANGLES	± 2'															
MATERIAL SEE NOTE		FINISH SEE NOTE	501-57118	RESTRICTED TO												
		WEIGHT	SIZE A3	CAGE CODE 00779												
		CUSTOMER DRAWING	DRAWING NO G=1734451	SCALE -												
			SHEET 1 OF 3	REV C												

THIS DRAWING IS UNPUBLISHED.

RELEASED FOR PUBLICATION

© COPYRIGHT BY TYCO ELECTRONICS CORPORATION. ALL RIGHTS RESERVED.

LOC DW
DIST

REVISIONS

P	LTR	DESCRIPTION	DATE	DWN	APVD
		SEE SHEET 1.			

TRAY PACKING:AS SHOWN

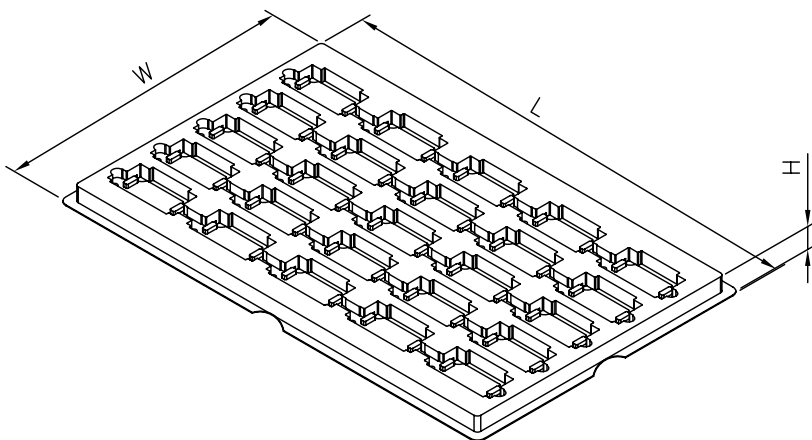
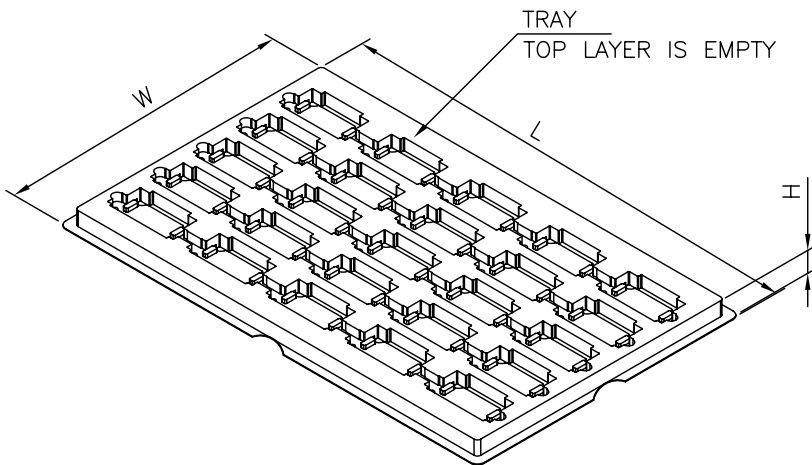

NOTES:

1. TRAY: PS.
SHIPPING CARTON: CORRUGATED FIBERBOARD
2. DIMENSION :
TRAY : L=346mm X W=215mm X H=7.5mm
SHIPPING CARTON : L=356mm, W=241mm, H=292mm
3. QUANTITY :
25 PCS/TRAY
40 TRAYS/SHIPPING CARTON (1,000PCS)
4. WEIGHT:
NET WEIGHT : 5.0 Kg
GROSS WEIGHT : 6.0 Kg

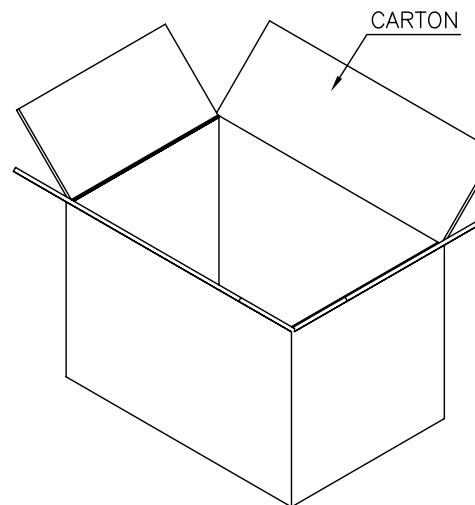

THIS DRAWING IS A CONTROLLED DOCUMENT.		DWN	Tyco Electronics Tyco Electronics Corporation Taipei, Taiwan	
DIMENSIONS: MM		CHK	NAME	
TOLERANCES UNLESS OTHERWISE SPECIFIED: 0 PLC ± - 1 PLC ± - 2 PLC ± - 3 PLC ± - 4 PLC ± - ANGLES ± -		APVD	PIN HEADER SLIM TYPE, 50 POS, TOP BOARD, COMPACT FLASH CARD	
MATERIAL		PRODUCT SPEC	SIZE	RESTRICTED TO
FINISH		APPLICATION SPEC	CAGE CODE	
		WEIGHT	DRAWING NO	
		CUSTOMER DRAWING	A3 00779	©=1734451
		SCALE	SHEET	REV
			2 OF 3	C

THIS DRAWING IS UNPUBLISHED.

RELEASED FOR PUBLICATION

© COPYRIGHT BY TYCO ELECTRONICS CORPORATION. ALL RIGHTS RESERVED.

LOC DW DIST

REVISIONS

P	LTR	DESCRIPTION	DATE	DWN	APVD
		SEE SHEET 1.			

TAPE AND REEL PACKING : AS SHOWN

NOTE:

- PACKAGING MATERIAL IN PLASTIC, RUBBER, INK, PIGMENT AND PAINT MUST MEET CONTROLLED SUBSTANCES TE SPEC PER 230-702.
 - * CADMIUM AND CADMIUM COMPOUNDS NOT TO EXCEED: 5 PPM.
 - * LEAD, CADMIUM, CHROM VI AND MERCURY NOT TO EXCEED: 100 PPM (COMBINED).
- EACH BAG SHALL BE INCLUDED:
 - * DESICCANT
 - * HUMIDITY INDICATOR CARD
 - * MOISTURE SENSITIVITY LABEL
- CARRIER TAPES, COVER TAPES, REELS AND TAPED COMPONENTS MUST MEET THE REQUIREMENTS DEFINED PER EIA-481-B.
- CARTON MATERIAL : CORRUGATED FIBERBOARD
TAPE&REEL MATERIAL : PS
- PEELING RESISTANCE : 0.1N~1.5N(10g~150g)
PEELING SPEED : 300mm/MIN

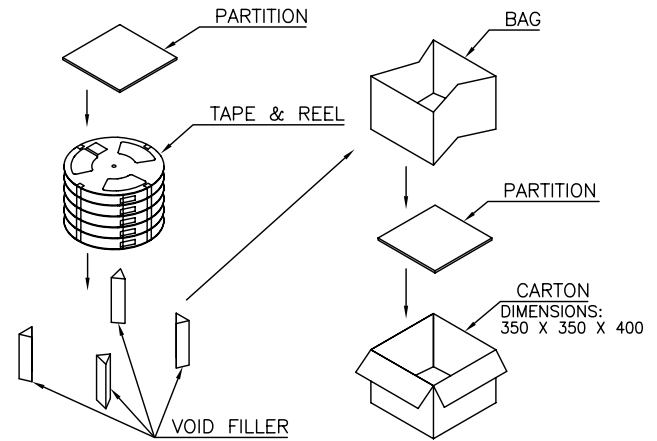
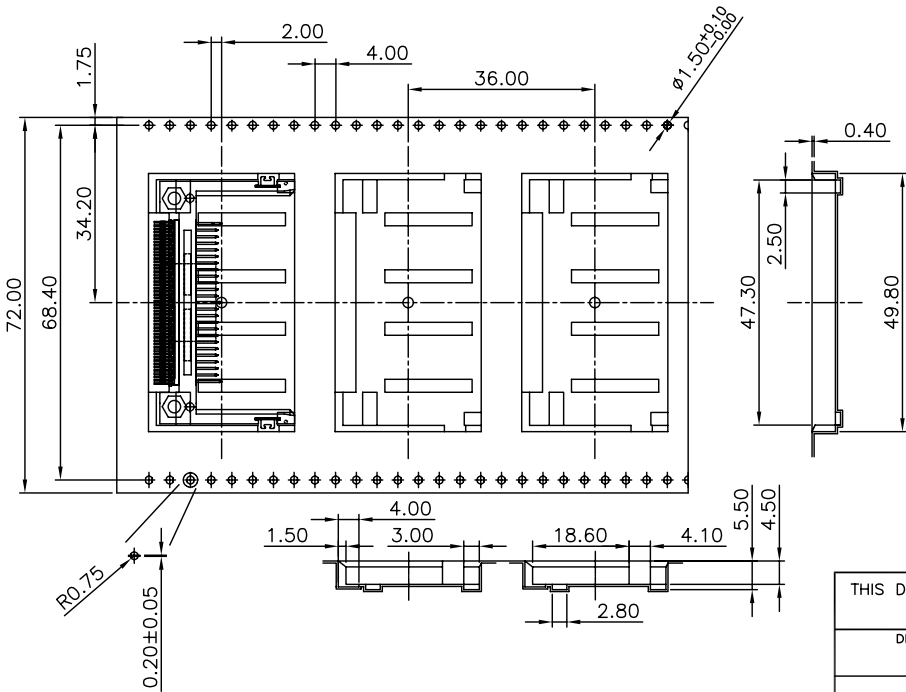
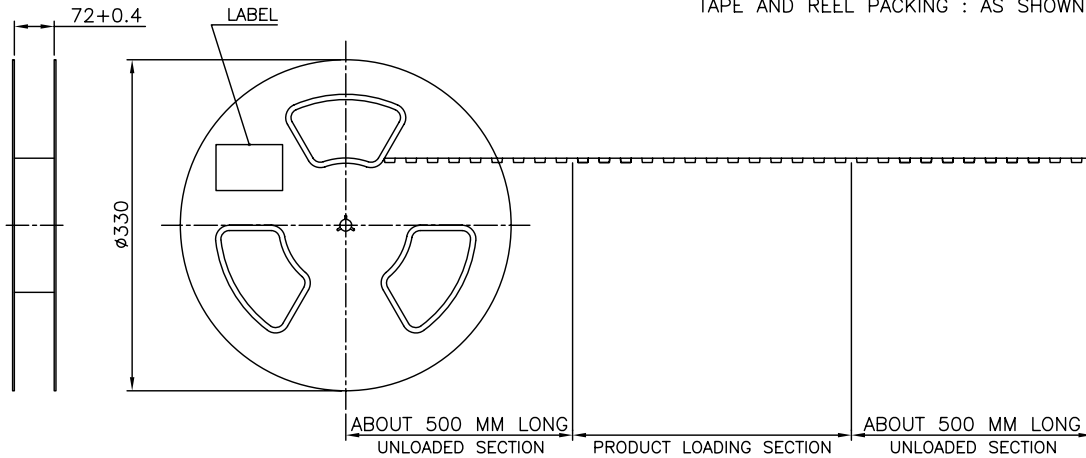

PCS/TAPE	REELS/CARTON	QUANTITY (PCS)	G/W (Kg)	N/W (Kg)
200	5	1000	3.45	7.9

THIS DRAWING IS A CONTROLLED DOCUMENT.

Tyco Electronics Tyco Electronics Corporation
Taipei, Taiwan

NAME: PIN HEADER SLIM TYPE, 50 POS, TOP BOARD, COMPACT FLASH CARD

SIZE: A3 CAGE CODE: 00779 C=1734451 DRAWING NO: 1734451

CUSTOMER DRAWING SCALE: SHEET: 3 of 3 REV: C

DWN	CHK	APVD	PRODUCT SPEC	APPLICATION SPEC	WEIGHT

DIMENSIONS: MM	TOLERANCES UNLESS OTHERWISE SPECIFIED:
	0 PLC ± -
	1 PLC ± -
	2 PLC ± ±0.5
	3 PLC ± -
	4 PLC ± -
	ANGLES ± -
MATERIAL	FINISH